

ESDA Standards Organization – 33 Working Groups

- WG1 – Wrist straps
- WG2 – Garments
- WG3 – Ionization
- WG4 – Work Surfaces
- WG6 – Grounding
- WG7 – Flooring
- WG8 – Symbols
- WG9 – Footwear
- WG11 – Packaging
- WG12 – Seating
- WG13 – Hand Tools
- WG15 – Gloves
- WG17 – Process Assessment
- WG19 – High Reliability
- WG20 – ESD Control Program (S20.20)
- WG28 – ESA
- WG29 – Healthcare
- WG53 – Compliance verification
- WG97 – Footwear/Flooring systems

Manufacturing
controls

Device &
Silicon

- WG5 – Device Testing
- WG5.4 – TLU
- WG5.5 – TLP
- WG5.6 - HMM
- JWG HBM (joint with JEDEC)
- JWG CDM (joint with JEDEC)
- WG14 – System ESD
- WG18 – EDA
- WG21 – Flat Panel
- WG22 – Foundry Parameters
- WG23 – EOS Best Practices
- WG25 – Charged Board
- WG26 – System ESD Modeling
- WG27 – Automotive EOS

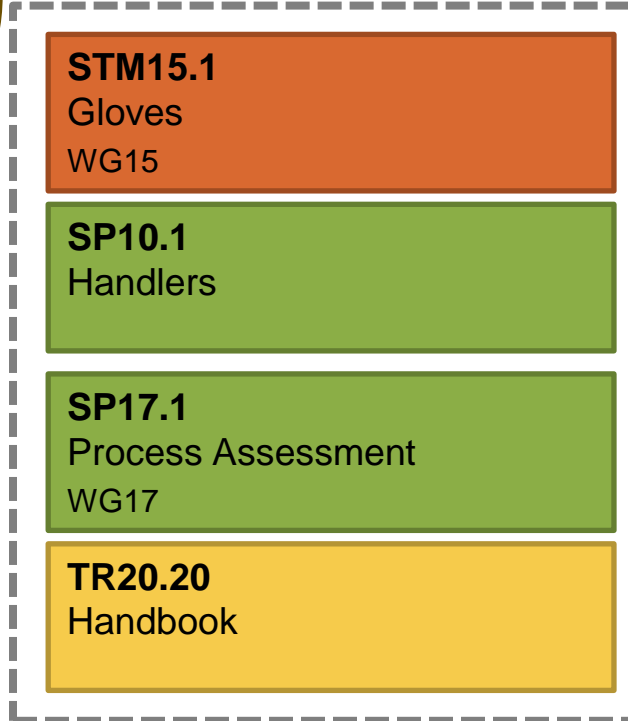
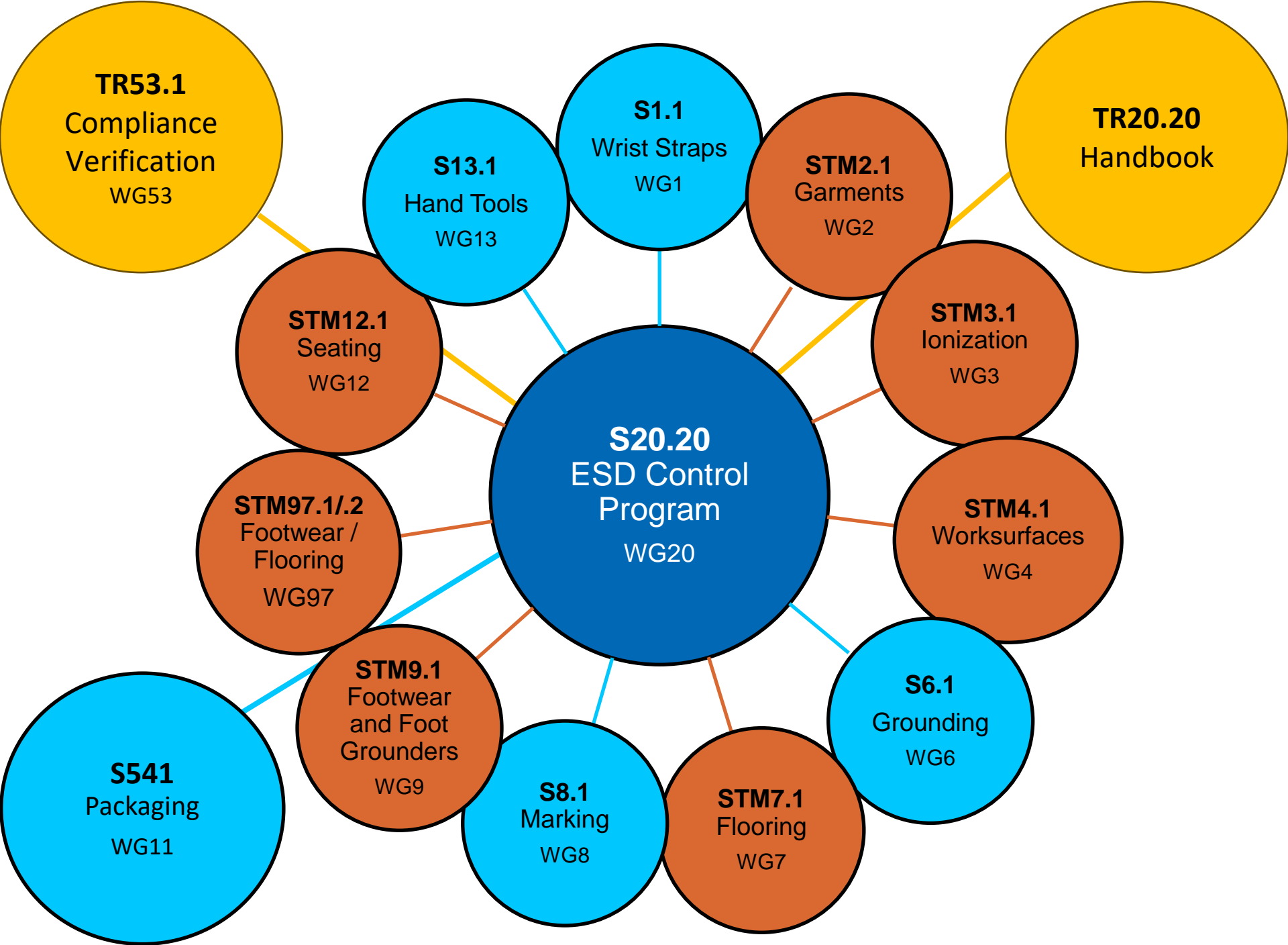

Annex A of S20.20
Annex B of S20.20

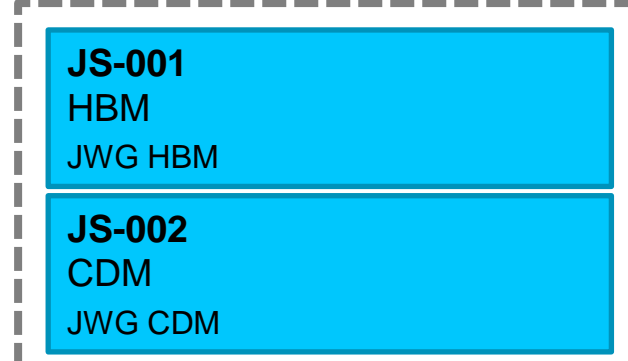

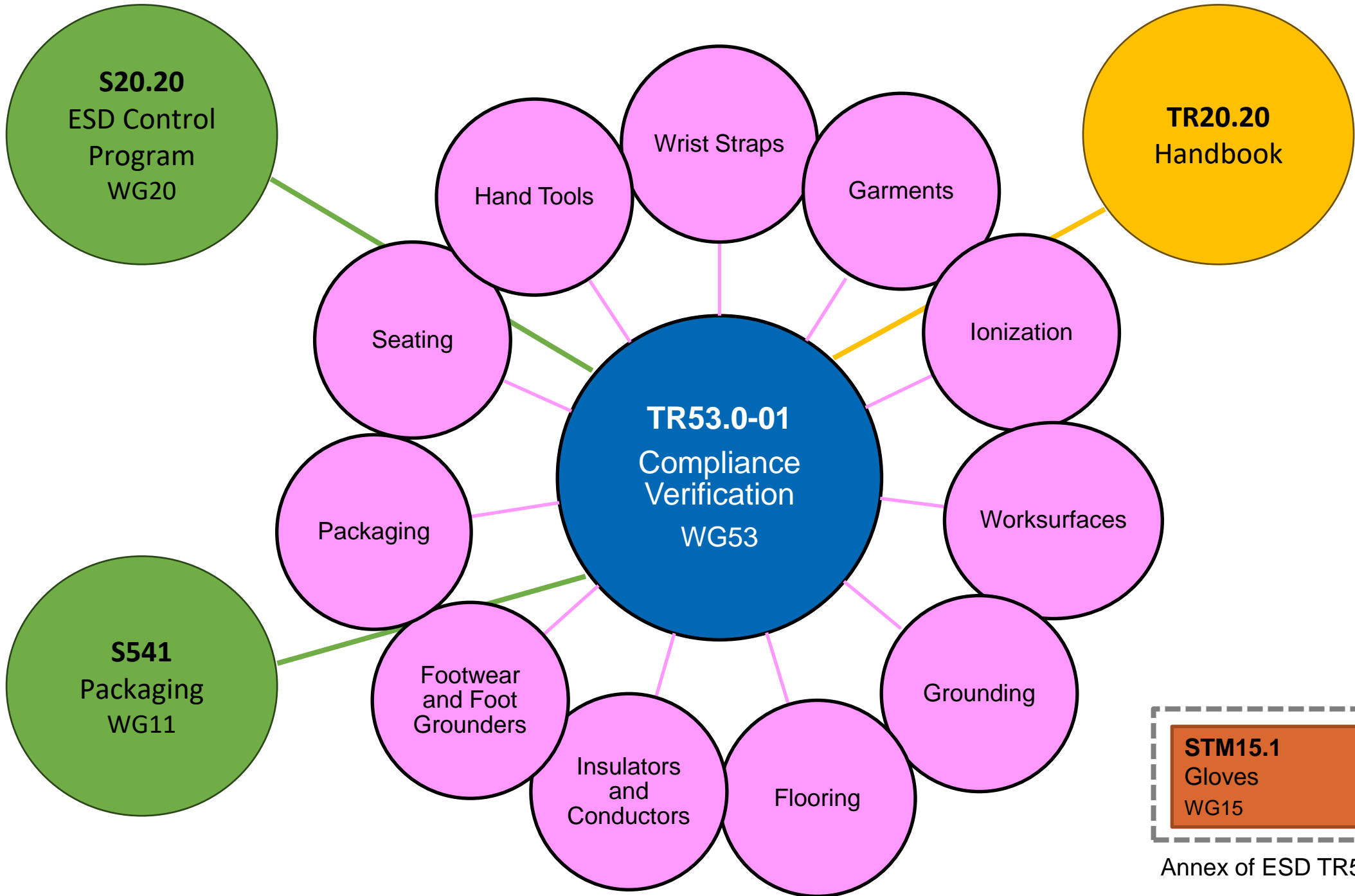

Annex of ESD TR53.0-01

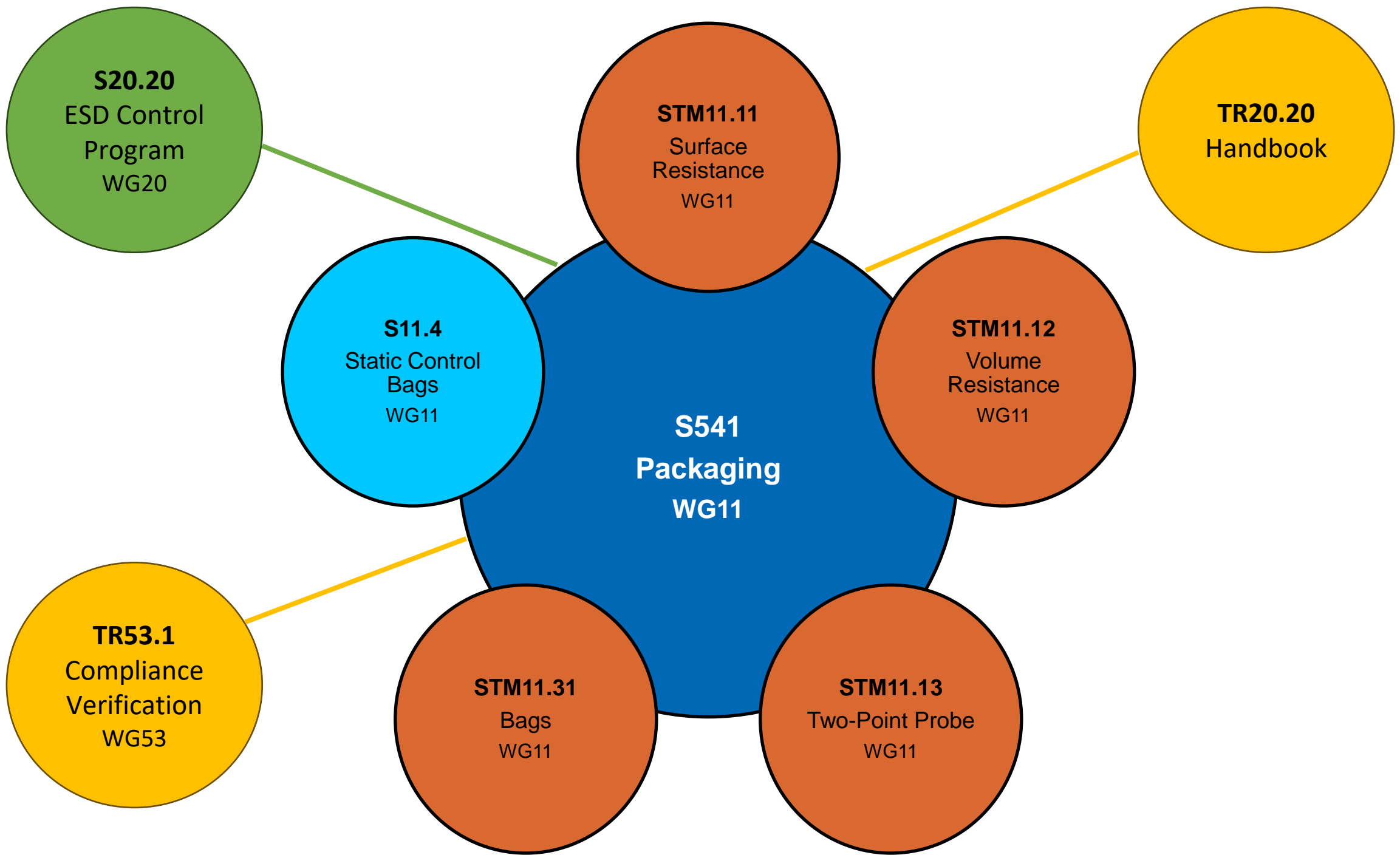

Device Standards Structure

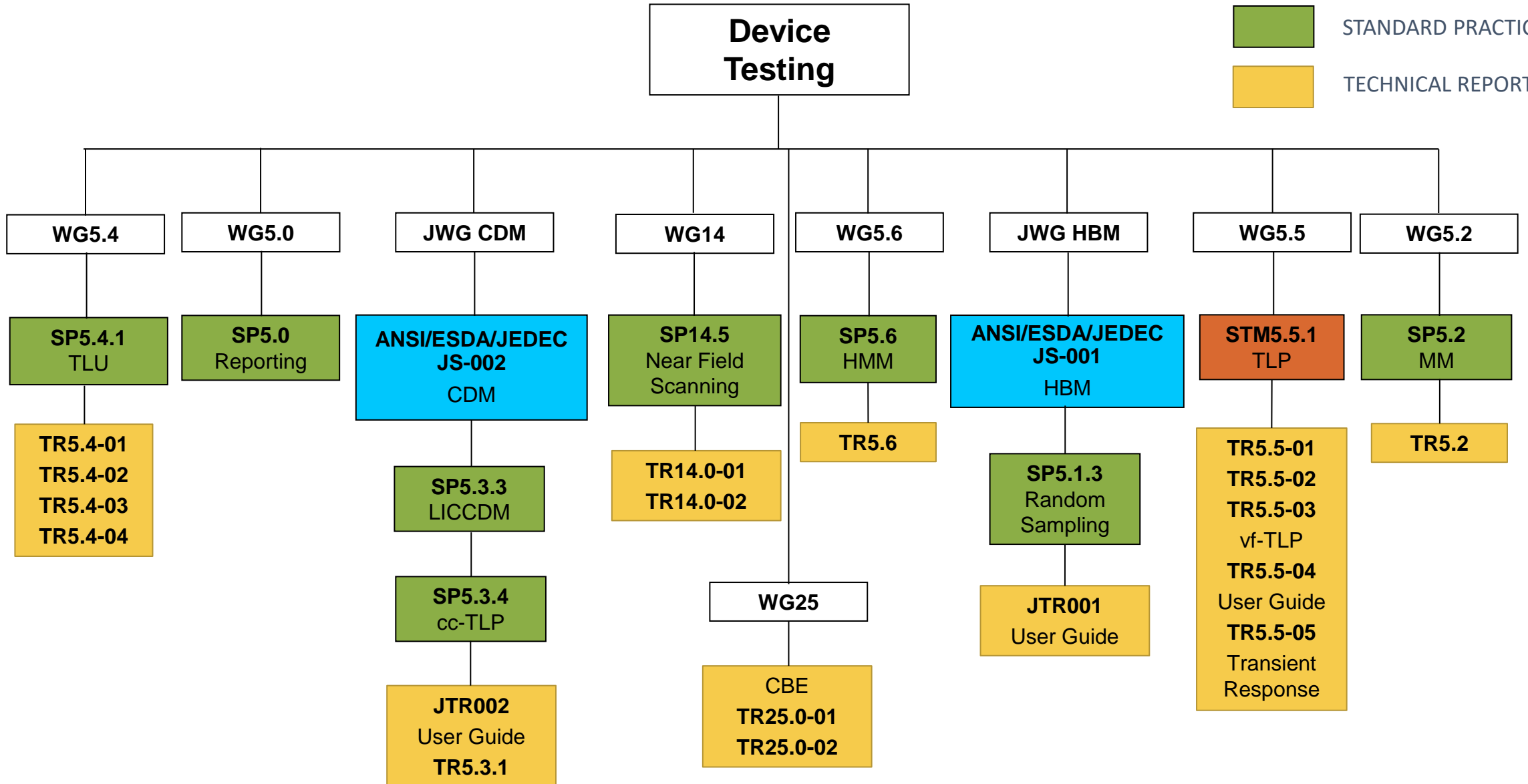

Device Standards Structure

